

Power Relay Series – H3F-S-DC-12V-C

FEATURES特点

- Up to 15A contact switching capability
高达15A触点切换能力
- 1 Form A and 1 Form C configurations
具有一组常开、一组转换触点形式
- Sockets available
配有多种插座可供选择
- Overall dimensions (19.6X15.4X15.5) mm.
外形尺寸 (19.0X15.4X15.5) mm。

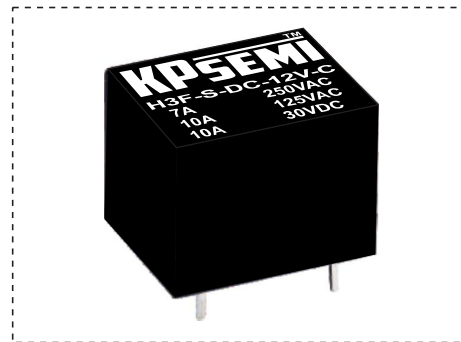

CONTACT PARAMETERS触点参数

Contact Form触点形式	A-1组常开 B-1组常闭 C-1组转换
Rating Load (Resistive) 额定负载 (阻性)	A型: 10A 250VAC 15A 125VAC C型: NO: 10A 250VAC NC: 7A 250VAC
Max. Switching Current最大切换电流	15A
Max. Switching Voltage最大切换电压	277VAC/28VDC
Max. Switching Power最大切换功率	2770VA/280W

CHARACTERISTICS性能参数

Contact Materials触点材料	Ag Alloy银合金	
Contact Resistance接触电阻	100mΩ Max	
Operate Time吸合时间	10ms. Max	
Release Time释放时间	5ms. Max	
Insulation Resistance绝缘电阻	100MΩ Min. (DC500V)	
Initial Dielectric Strength介质耐压	between open contacts: 触点与触点间:	AC 750V, 50/60Hz 1Min
	between contacts and coil: 触点与线圈间:	AC1,500V, 50/60Hz 1Min
Vibration Resistance抗振动	Damage limits: 耐久:	10~55Hz Double Amplitude双振幅1.5mm
	Malfunction: 误动作:	10~55Hz Double Amplitude双振幅1.5mm
Shock Resistance抗冲击	Damage limits: 耐久:	100G Min
	Malfunction: 误动作:	10G Min
Life寿命	Mechanical Life (10800 per hour) 机械寿命 (每小时10800次)	1×10 ⁷
	Electrical Life (1800 per hour) 电气寿命 (每小时1800次)	1×10 ⁵
Ambient Temperature环境温度	-40°C ~ +105°C (No condensation) (不冷凝)	
Unit Weight单位重量	约Approx. 10.0g	

COIL RATINGS (at23°C) 线圈参数 (在23°C)

Coil Nominal Voltage 额定电压 (VDC)	Nominal Current 额定电流 ±10%(mA)	Coil Resistance 线圈电阻 ±10% (Ω)	Max. Continuous Voltage 最大连续外加电压	Pick-Up Voltage 吸合电压 (Max)	Drop-Out Voltage 释放电压 (Min)	Rated power 额定功率
3	120.00	25	Coil Nominal Voltage 130% 额定电压的 130%	Coil Nominal Voltage 75% 额定电压的 75%	Coil Nominal Voltage 10% 额定电压的 10%	About 0.36 W 约0.36W
5	71.42	70				
6	60.00	100				
9	40.00	225				
12	30.00	400				
15	24.00	625				
18	20.00	900				
24	15.00	1,600				
48	7.50	6,400				
3	120.00	25				
5	71.42	70	Coil Nominal Voltage 130% 额定电压的 130	Coil Nominal Voltage 75% 额定电压的 75%	Coil Nominal Voltage 10% 额定电压的 10%	About 0.45 W 约0.45 W
6	60.00	100				
9	40.00	225				
12	30.00	400				
15	24.00	625				
18	20.00	900				
24	15.00	1,600				
48	7.50	6,400				

ORDERING INFORMATION 订货标记

H3F-S-DC-12V-C-D-(XXX) <u>1</u> <u>2</u> <u>3</u> <u>4</u> <u>5</u> <u>6</u>	
1. Model Number基本型号 H3F 2. Encapsulation form:S-Plastic Sealed SH:Fluk proofed 封装形式: S-塑封型 SH-防焊剂型 3. Coil Voltage线圈规格 (VDC): DC3V,DC5V,DC6V,DC9V,DC12V,DC15V,DC18V, DC24V,DC48V	4. Contact form: A-1Form A, B-1Form B, C-1Form C 触点形式: A-1组常开 B-1组常闭 C-1组转换 5. Coil Power:No - 0.36 W, D-0.45W 线圈功率:无-0.36W, D-0.45W 6. Customer Special Code :XXX-Customer Special Requirements No - Standard Type 客户特性号: XXX-客户特殊要求, 无-标准型

SAFETY STANDARD安规认证

AuthType Basic认证类别	CQC	TUV	UL/C__UL
Authentication Load 认证负载	10A 250VAC	10A 250VAC	15A 125VAC

OUTLINE DIMENSIONS (UNIT:mm)外形尺寸 (单位: mm)

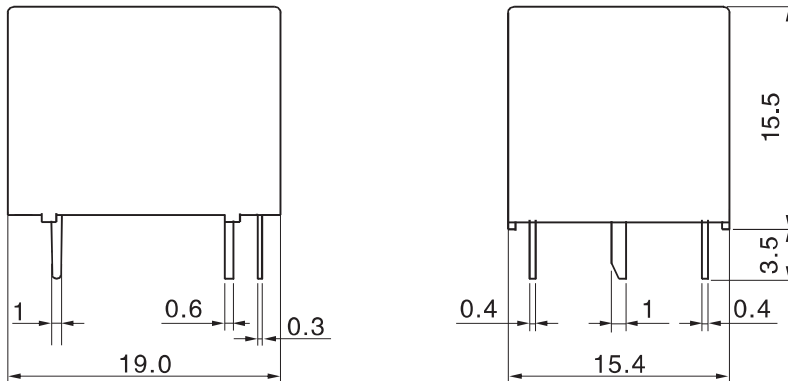

Undimensioned tolerance: <1mm: ±0.2mm 1~5mm: ±0.3mm >5mm: ±0.4mm
 未标注尺寸公差: <1mm: ±0.2mm 1~5mm: ±0.3mm >5mm: ±0.4mm

Note: 1.The size of the lead foot is pre welding dimension. 注: 1、引出脚尺寸为预焊前尺寸
 2.installation hole size tolerance: +0.1mm 2、安装孔尺寸公差: ±0.1mm

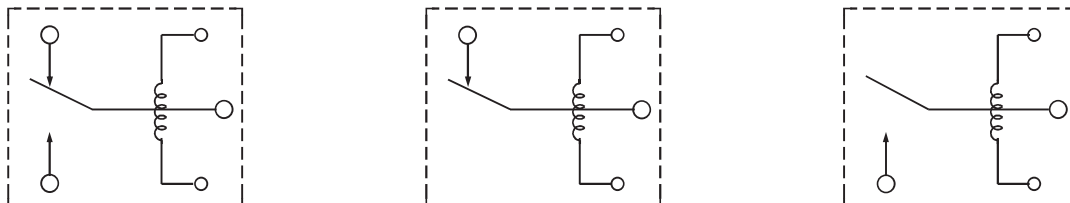

Wiring diagram (bottom view)
接线图 (底视图)

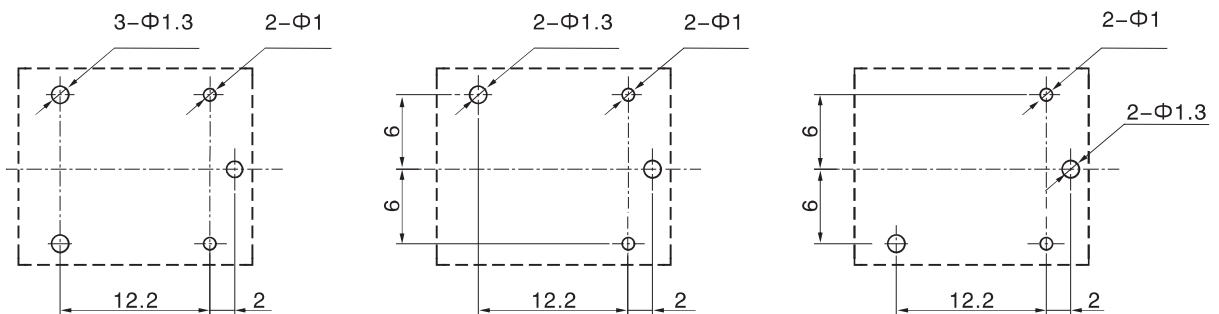

Mounting hole size (bottom view)
安装孔尺寸 (底视图)

TYPICAL USE典型用途

- 家用电器: 空调、电热器等 Vending Machines
- 办公室设备: 电脑、传真机等 Office equipment: Computer, Fax, Etc..
- 智能家居产品 Smart Home Products

PERFORMANCE CHART性能曲线图

