

Description

The KP6207 series is a high input voltage, low quiescent current, low-dropout linear regulator able to provide 300mA load current. The LDO features very fast response against line voltage transient and load current transient, and ensures no overshoot voltage during the LOD start up and short circuit recovery. The device features integrated short-circuit and thermal shutdown protection.

Features

- High Input Voltage Rating: Up to 18V
- Maximum Output Current: 150mA
- Standard Fixed Output Voltage Options: 3.0V, 3.3V
- Low Quiescent Current: 2.1uA
- PSRR=85dB@1KHz
- Low Dropout: 350mV@100mA
- Low Output Voltage Accuracy: $\pm 1\%$
- Fast Transient Response
- Thermal Shutdown Protection, Current Limiting Protection
- Available Packages: SOT-23

Applications

- ① Battery-Powered Equipment
- ② Smoke Detector and Sensor
- ③ Micro Controller Applications

Typical Application Circuit

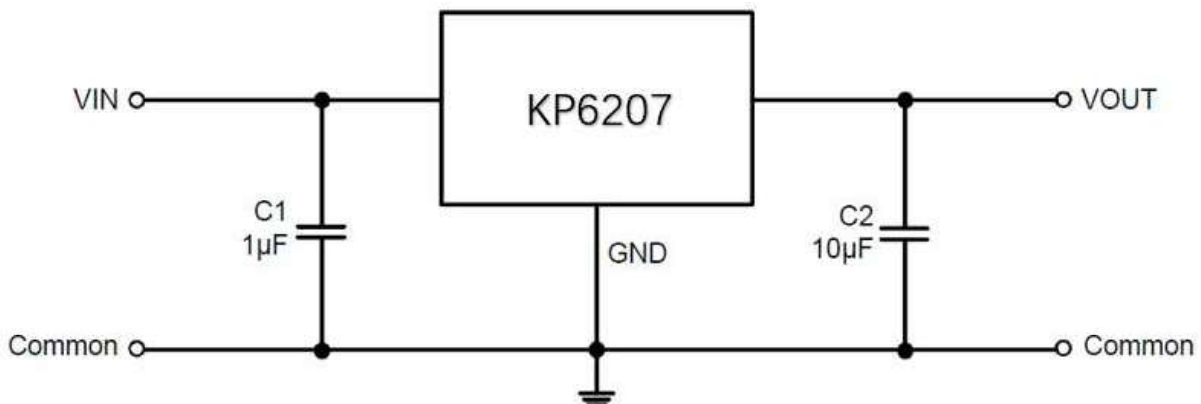

Pin Distribution

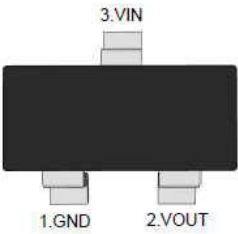
PACKAGE	PIN	NAME	DESCRIPTION
	1	VSS	GND
	3	VIN	POWER INPUT
	2	VOUT	VOLTAGE OUTPUT

Ordering Information

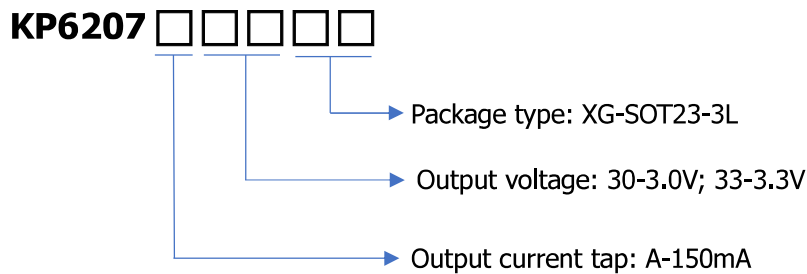

Orderable Device	Package	Reel(inch)	Package Qty (PCS)	Eco Plan ^{Note1}	MSL Level
KP6207A30	SOT23-3L	7/13	3000	RoHS & Green	MSL1
KP6207A33					

Note1:

RoHS: KP defines "RoHS" to mean semiconductor products that are compliant with the current EU RoHS requirements for all 10 RoHS substances, including the requirement that RoHS substance do not exceed 0.1% by weight in homogeneous materials.

Green: KP defines "Green" to mean Halogen-Free and Antimony-Free.

Recommended Operating Conditions

Parameter	Value	Unit
Supply Voltage	3-18	V
Maximum Output Current	150	mA
Operating Ambient Temperature	-40 ~ +85	°C

Function Block Diagram

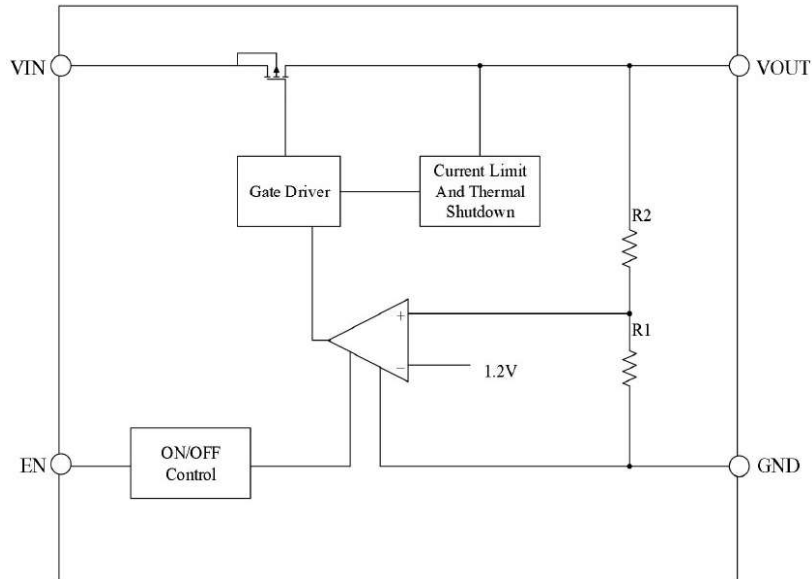

Absolute Maximum Ratings ^{Note2}

Ratings at 25°C ambient temperature unless otherwise specified

Parameter		Value	Unit
Vin to GND Voltage		-0.3 ~ +18	V
Vout to GND Voltage		-0.3 ~ +6	V
Vout to Vin Voltage		-18 ~ +0.3	V
Output Current		Internally limited	--
Power Dissipation	SOT-23	320	mW
Thermal Resistance, Junction-to-Ambient	SOT-23	380	°C/W
Operating Ambient Temperature		-40 ~ +85	°C
Junction Temperature		150	°C
Storage Temperature Rangd		-40 ~ +150	°C

Note2: Exceed these limits to damage to the device, exposure to absolute maximum rating conditions may affect the reliability of the chip.

Electrical Characteristics

($V_{INs}=7V$, $C_{IN}=C_{OUT}=10\ \mu F$, $T_A=25^\circ C$,)

Item	Symbol	Conditions	Min	Type	Max	Units
Input voltage range	V_{IN}				18	V
Output voltage range	V_{OUT}		3		5	V
Output voltage tolerance	ΔV_{OUT}	$V_{IN}=V_{OUT}+1V$	-2		2	%
Drop voltage difference	V_{DROP}	$V_{OUT}=3V$, $I_{OUT}=100mA$		550		MV
		$V_{OUT}=3V$, $I_{OUT}=150mA$		800		MV
Quiescent current	I_Q	$T_J = 25^\circ C$		2	4	UA
Line adjustment rate	ΔV_{LINE}	$V_{IN} = V_{OUT} + 2V$ to $18V$ $I_{OUT} = 10mA$			0.2	%V
Load adjustment rate	ΔV_{LOAD}	$I_{OUT} = 0mA$ to $150mA$ $V_{IN}=V_{OUT} +2V$		13	33	MV
Limited current	I_{CL}	$V_{IN}=V_{OUT}+3V$	150			MA
Ouput short current	ISH	$V_{IN}=V_{OUT}+3V$		75		MA
Ripple suppression ratio	PSRR	$f = 1kHz$		48		dB
		$f = 10kHz$		38		dB
Overtemperature protection	TOCP			150		$^\circ C$
	THD			30		$^\circ C$

Characteristic Curve

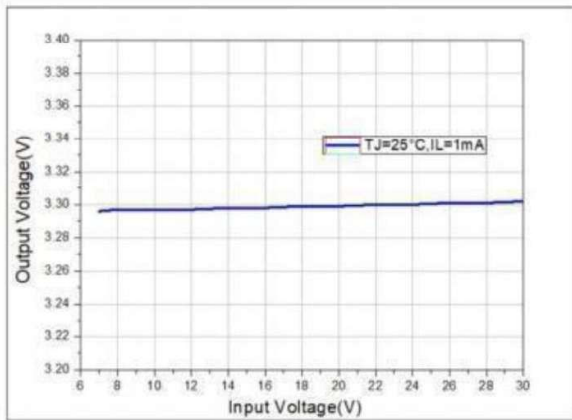

Fig 1 V_{OUT} VS V_{IN}

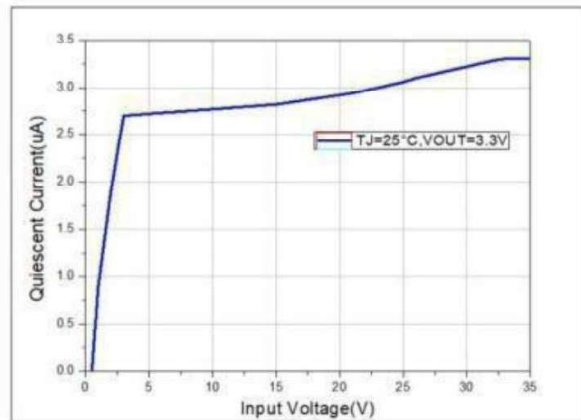

Fig 2 I_Q VS V_{IN}

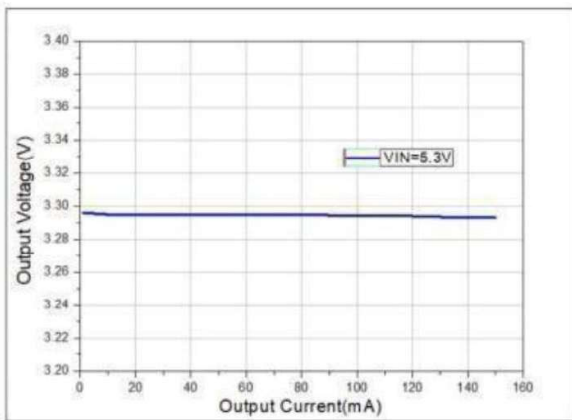

Fig 3 V_{OUT} VS I_{OUT}

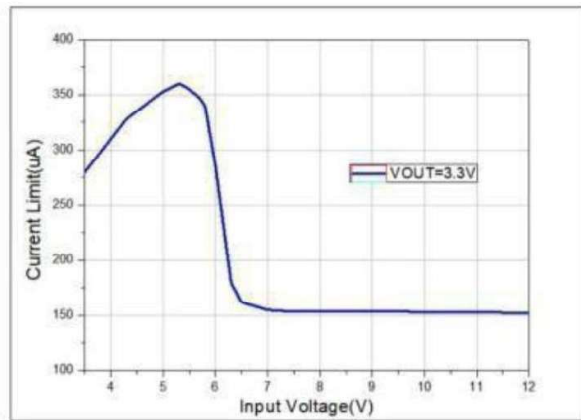

Fig 4 I_{limit} VS V_{IN}

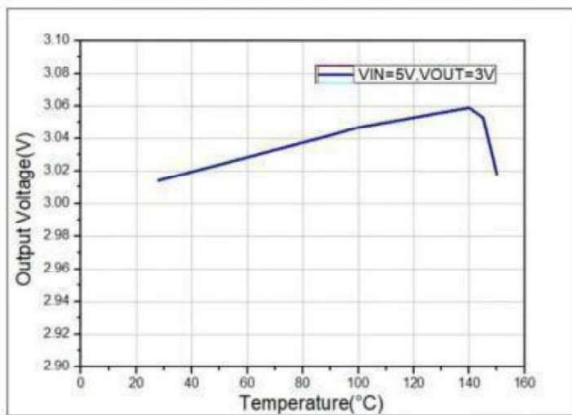

Fig 5 V_{OUT} VS Temperature

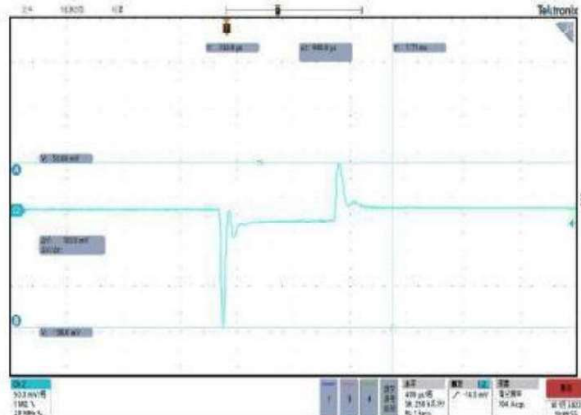

Fig 6 Load Transient

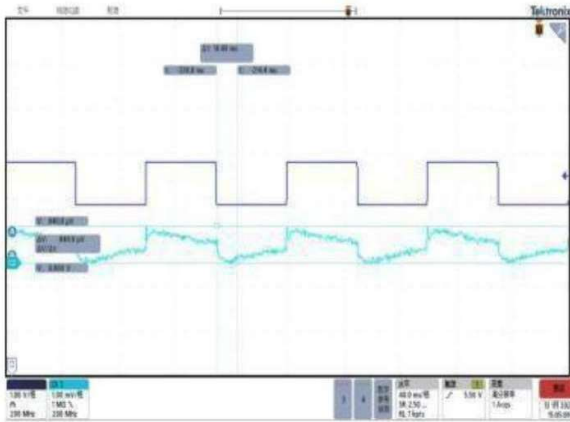

Fig 7 Input Transient

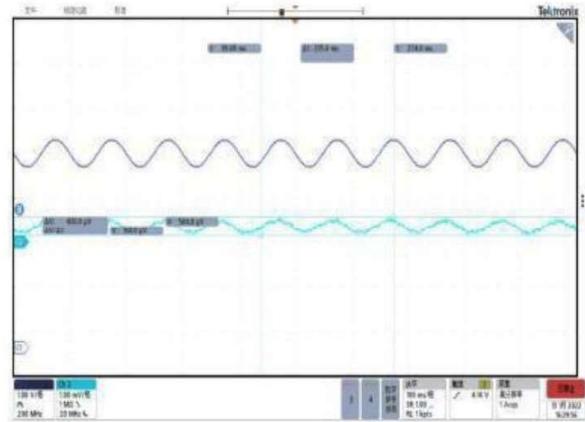

Fig 8 PSRR=61.5dB(f=10Hz)

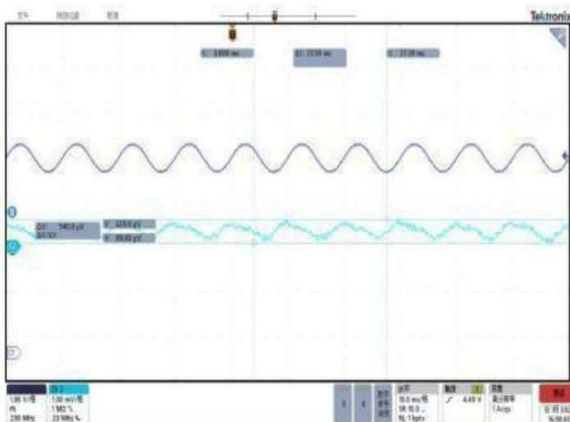

Fig 9 PSRR=59.3dB(f=100Hz)

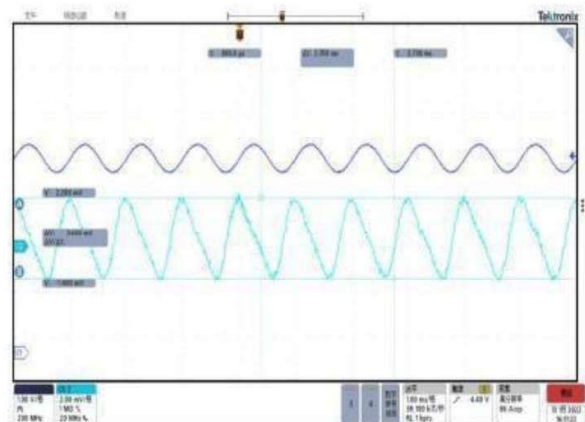

Fig 10 PSRR=42.8dB(f=1KHz)

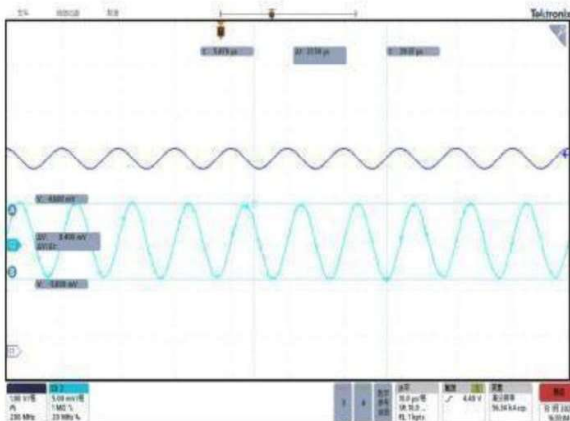

Fig 11 PSRR=35.5dB(f=100KHz)

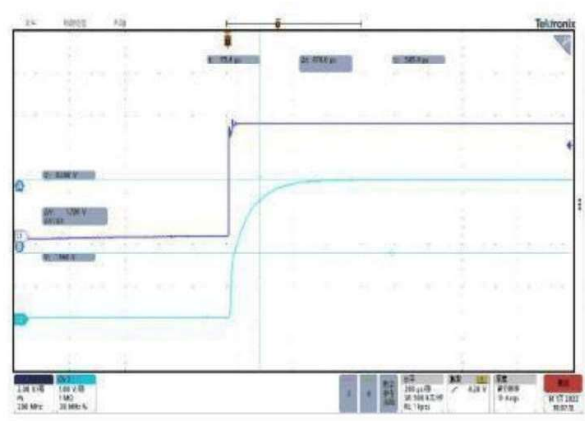

Fig 12 Output overshoot

Functional Description

Input Capacitor

A 1 μ F ceramic capacitor is recommended to connect between Vin and GND pins to decouple input power supply glitch and noise. The amount of the capacitance may be increased without limit. This input capacitor must be located as close as possible to the device to assure input stability and less noise. For PCB layout, a wide copper trace is required for both Vin and GND.

Output Capacitor

An output capacitor is required for the stability of the LDO. The recommended minimum output capacitance is 10 μ F, ceramic capacitor is recommended, and temperature characteristics are X7R or X5R. Higher capacitance values help to improve load/line transient response. The output capacitance may be increased to keep low undershoot/overshoot. Place output capacitor as close as possible to Vout and GND pins.

Current Limit and Short Circuit Protection

When output current Vout pin is higher than current limit threshold or the Vout pin is direct short to GND, the current limit protection will be triggered and clamp the output current at a pre-designed level to prevent over-current and the thermal damage.

Thermal Protection

The KP6207 series has internal thermal sense and protection circuits. When excessive power dissipation happens on the device, such as short circuit at the output pin or very heavy load current with a larger voltage drop across the device, the internal thermal protection circuit will be triggered, and it will shut down the power MOSFET to prevent the LDO from damage. As soon as excessive thermal condition is removed and the temperature of the device drops down, the thermal protection circuit will release the control of the power MOSFET, and the LDO device goes to normal operation.

Package Outline

SOT-23

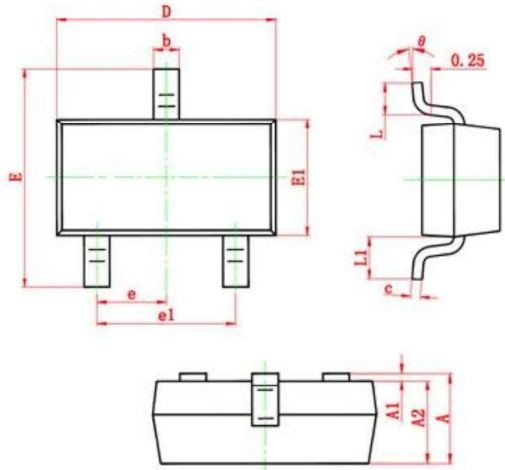

Symbol	Dimensions In Millimeters		Dimensions In Inches	
	Min.	Max.	Min.	Max.
A	0.900	1.150	0.035	0.045
A1	0.000	0.100	0.000	0.004
A2	0.900	1.050	0.035	0.041
b	0.300	0.500	0.012	0.020
c	0.080	0.150	0.003	0.006
D	2.800	3.000	0.110	0.118
E	2.250	2.550	0.089	0.100
E1	1.200	1.400	0.047	0.055
e	0.950 TYP.		0.037 TYP.	
e1	1.800	2.000	0.071	0.079
L	0.300	0.500	0.012	0.020
L1	0.550 REF.		0.022 REF.	
θ	0°	8°	0°	8°

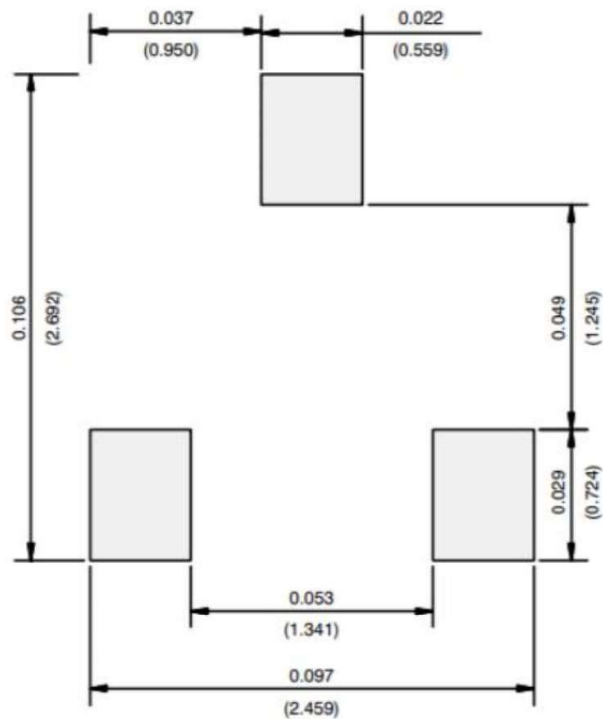

Recommended Minimum Pads
Dimensions in Inches/(mm)